

45.30



**DIECI**

# PEGASUS 45.30

Preliminary

## DIMENSIONS

A	400
B	3230
C	3300
D	1870
E	1955
F	5850
G	8400
H	3095
I	980
L	2000
M	2500
N	5625
O	5960
P	1535
Q	4400
R	4915

Measurements expressed in millimetres

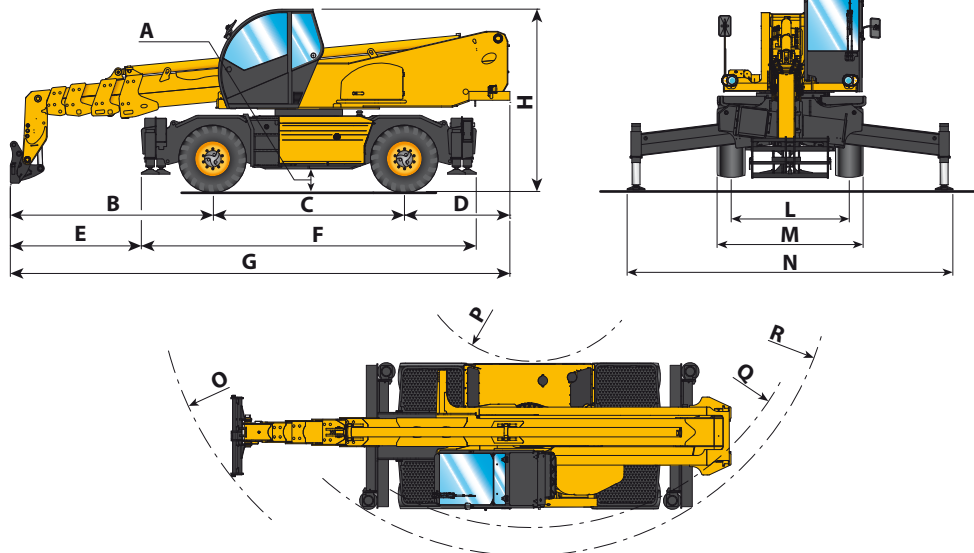

## PERFORMANCE

Maximum capacity (kg)	4.500
Maximum lifting height (m)	29,60
Maximum horizontal outreach (m)	25,50
Outreach at maximum height (m)	5,6
Fork swivelling angle	115°
Pull-out force (daN)	5.700
Towing force (daN)	10.000
Maximum climb angle	40%
Total weight empty (kg)	22.000
Max speed (km/h)	40*

\* referred to wheels having the maximum allowable diameter

## BOOM

Times: empty (in seconds)	
Lifting	14,5
Descent	9,5
Extension	29
Retraction	14
Forward swivelling	2,1
Reverse swivelling	1,3

Patented compensation system

## HYDRAULIC PLANT

Load sensing variable displacement pump	
Gear pump with capacity at max speed (lt/1')	290
Max working pressure (bar)	250
Control valve with joystick	5 in 1 proportional
Simultaneous movements	5
Proportional control distributor "Load Sensing" with "Flow Sharing"	

## DIFFERENTIAL AXLES

Steering axles: 2, with planetary reduction gears	
Steering types: 4 wheels / transversal / 2 wheels	
Front axle: levelling	
Back axle: oscillating	
Oil bath service braking on the 4 wheels with double hydraulic plant and servo brake	
Negative action parking brake	

## REFUELLING (Litres)

Hydraulic plant (total)	320
Fuel tank	220
AdBlue tank	35

## ENGINE

Model:	FPT
Rated power kW (hp) @ 2200 rpm	125 (170)
Maximum power at 1900 rpm kW (hp)	127 (173)
Revolutions per minute (rpm):	2200
Operation:	4-stroke diesel
Injection:	Electronic direct, Common Rail
Number and arrangement of cylinders:	4, vertical in line
Engine size (cm <sup>3</sup> ):	4500
Specific consumption - (g/kWh) @ 1900 rpm	208
Anti-pollution regulation:	Stage 4 / Tier 4F

\* at maximum power

Aftercooler turbo compressor

Liquid cooling system

## OPTIONALS AND ACCESSORIES

A/C; water heater; pneumatic seat suspension; light on boom head; quick attachment for accessories; radio; anti-theft alarm; glass protection; Led work lights, Transverse levelling device on wheels and others...

(For further customised accessories, please consult your local dealer)

## TRANSMISSION

Hydrostatic transmission with continuous adjustment and electronic control

Hydrostatic engine with electronic control.

Electro-hydraulic reversing.

Inching pedal for controlled forward movement.

## SAFETY DEVICES

Movement block in case of overload, starting only with gear in neutral, running only with driver on board, automatic parking brake with engine stopped. Automatic transversal levelling with outriggers.

Stabilizers block and levelling device with boom up.

## DEVICES AS PER STANDARD

ROPS - FOPS approval, Suspension on silent-blocks, soundproofing, ventilation and heating, roof and openable rear glass, double-glaze door with top opening, adjustable seat with safety seatbelt, radio pre-arrangement, adjustable steering wheel.

Dual Monitor TFT7" + TFT3,5" with load indicator and functions diagnostic, tachometer analog gages, water temperature, fuel level and speed.

Turret rotation maximum speed adjustment. Digital tachometer.

## TYRES

Tyres	18R22.5"
Alternative	18-22.5"